

20120 ALUMINUM CANTILEVER LIFT

- OWNER AND OPERATORS MANUAL -
Model 20120

Maximum Load 2,000 Pounds - Inside Lift Width 120" (10 ft.)

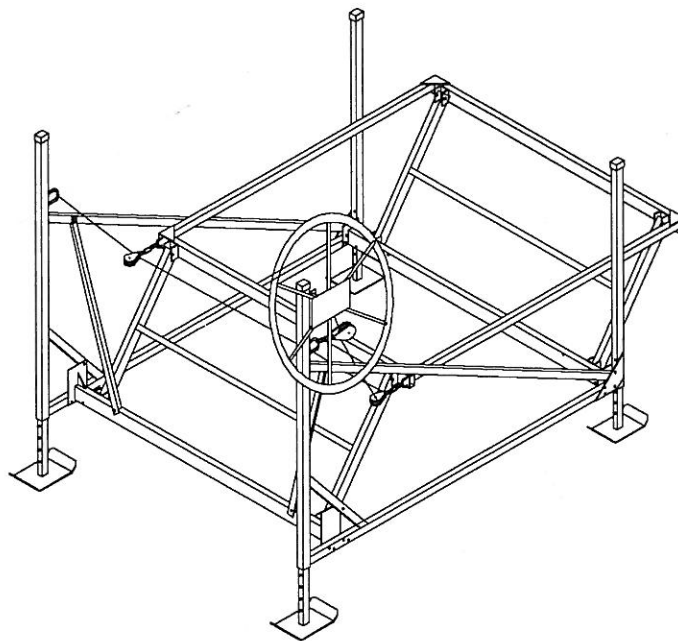

20120 Cantilever

Revision No. (1) 1-14-97

TABLE OF CONTENTS

<u>PAGE</u>	<u>SECTION</u>
3	Introduction
3	Warnings and Safety
4-5	Parts List 20120
6-14	Assembly 20120 Lift
15-16	Installation
17-19	Operation -Loading, Raising, Lowering
20	Removal and Storage
21	Service

INTRODUCTION

A aluminum 20120 cantilever lift will lift your boat up and out of the water for dockside storage. The 20120 is designed to rest on a stable lake bottom. This lift works best in non-fluctuating water with depths of over 2 ½ feet. There are maximum allowable water depths for the lift depending on leg lengths and location. A properly positioned lift provides safe, convenient, quick mooring for your craft.

The lift functions by turning the lift hand wheel clockwise to raise the lift. Properly position your boat in the lift and it will raise with the lift rack. The wheel is turned counterclockwise to lower the lift.

Information in this manual is not all inclusive and cannot cover all unique situations. If you have questions about assembly, installation, operation or suitability of this product contact your dealer or call (218) 739-4641.

WARNINGS AND SAFETY

Your **SAFETY** is the most important issue related to this product. It is critical that all assemblers, installers and users read and fully understand the warnings and safety information contained throughout this manual before using this product.

Safety Instructions

Never exceed recommended weight capacity of your lift. The weight of your boat includes the hull, engine, fuel, gear, battery, and added accessories. The dry weight reported by the manufacturer usually includes only basic boat and engine. The manufacturers reported weights can be understated by 10 -30%! This is before you add fuel, fluids, batteries, accessories, etc.! Weigh your boat at a certified scale to be absolutely sure of the total weight. You will be lifting 20 - 50% more than the reported dry weight when everything is considered.

- ✂ A properly educated or trained person is needed for assembly and installation of this product. Call if you have questions.
 - ✂ Wear proper protective clothing and eye wear when assembling or installing lift.
 - ✂ Do not assemble, install or use this product if items are missing or damaged.
 - ✂ If fast spin down of wheel occurs do not touch wheel or attempt to stop. Allow your boat to splash into water, it should not damage your boat! Placing hands or feet on spinning wheel can cause broken or cut limbs.
- ✂ **WARNING** - Stay clear of lift (facing wheel) while operating. Do not allow anyone on, in or under lift. A cable or lift part failure can cause a sudden drop of boat, resulting in a crushing or falling injury or death!
- ✂ Do not allow people on boat when it is on lift in raised position.
 - ✂ Do not make alterations or adjustments to lift or accessories when boat is on lift.
 - ✂ Check cable for frays, corrosion or breaks at least once a month. A cable breaking while boat is in lift could damage boat or lift. Severe bodily injury could also occur.

20120 LIFT PARTS LIST

Before assembly, identify each part. Remove parts from boxes, bags and bundles. Mark each item with the proper part letter (indicated in the left-hand column). This will confirm that all parts are here before beginning assembly and allows you to easily follow the assembly instructions.

****DO NOT CONFUSE I.D. STICKERS ALREADY PLACED ON PARTS. THESE LETTERS OR NUMBERS ARE FOR PACKING LIST IDENTIFICATION AND MAY NOT CONFORM TO I.D. LETTERS OR NUMBERS USED IN THIS INSTRUCTION MANUAL.**

Tools Needed For Assembly

20120 Winch Box & Bolt Bag:

Part ID	Qty.	Description
AA	2	Pulley with 3 Link Chain
BB	1	Pulley with 2 Link Chain
CC	1	Cable (1/4" x 26')
DD	1	DL Winch (2503 series)
EE	4	#2 Black Caps
GG	1	Wheel to Winch Bolt Kit

2 - 9/16" Combo Wrench

1 - 7/16" Combo Wrench

1 - 3/16" Allen Wrench

2 - 6' Pieces of Strong Nylon Rope

Bolt Bag:

24 - 3/8" x 2 3/4" Hex Bolts

2 - 3/8" x 3 1/2" Hex Bolts

2 - 3/8" x 4" U- Bolts

2 - 7/16" Off Set U-Bolts

8 - 1/2" x 4 1/2" Hex Bolts

2 - 1/4" Cable Clamps

30 - 3/8" Nuts

4 - 7/16" Nuts

8 - 1/2" Locking Nuts

10 - 3/8" Washers

4 - 7/16" Washers

Part A
Left Lift Side
Qty 1

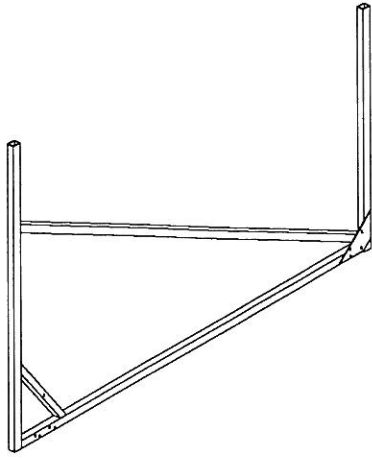

Part B
Right Lift Side
Qty 1

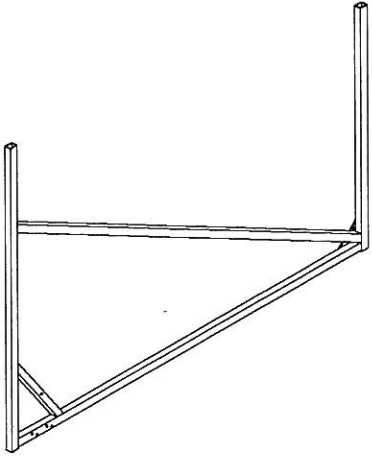

Part C
Legs
Qty 4

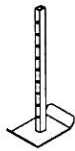

Part E
Front Bottom Beam
Qty 1

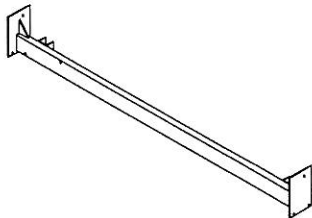

Part F
Rear Bottom Beam
Qty 1

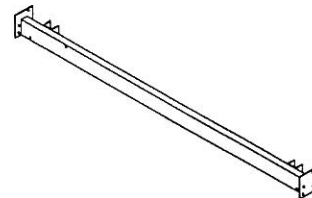

5

Part G
I Beam
Qty 2

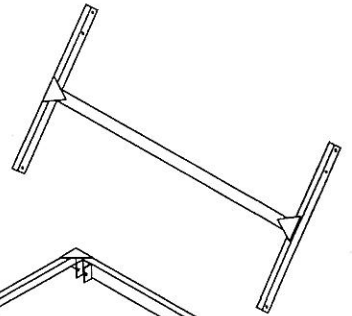

Part H
Top Rack
Qty 1

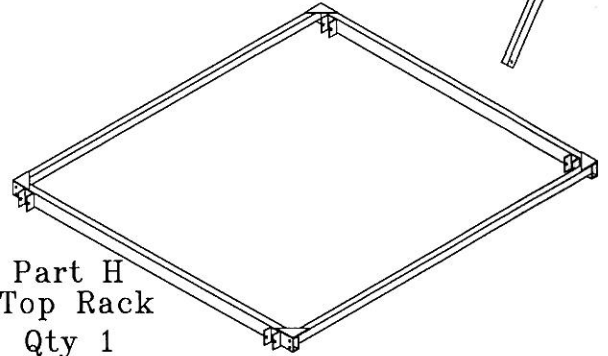

Part I
Left Side Brace
Qty 1



Part J
Right Side Brace
Qty 1

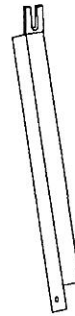

Part L
Wheel
Qty 1

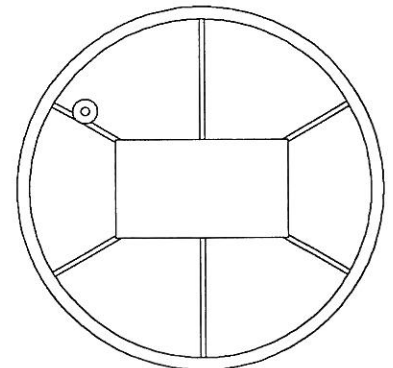

ASSEMBLY OF 20120 LIFT

****Fully read and understand each step before proceeding with that step.**

****Only hand tighten bolts and nuts until lift is completely assembled.**

#1 Slide EE parts (black caps) on uprights as shown.

#2 Insert (4) C parts (lift legs) into parts A and B (left and right side) as shown and secure in place using (4) $\frac{3}{8}$ " x $2\frac{3}{4}$ " hex bolts and (4) $\frac{3}{8}$ " nuts.

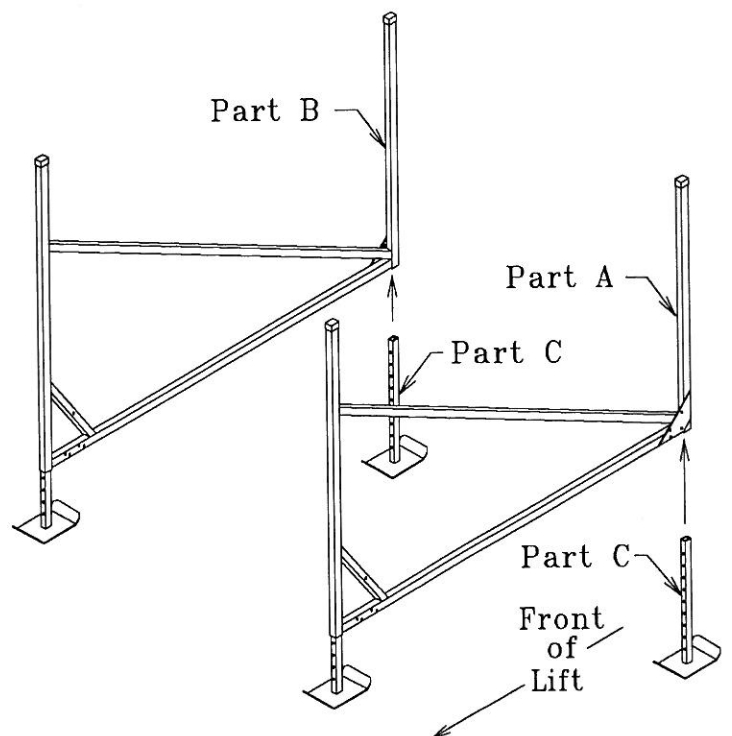
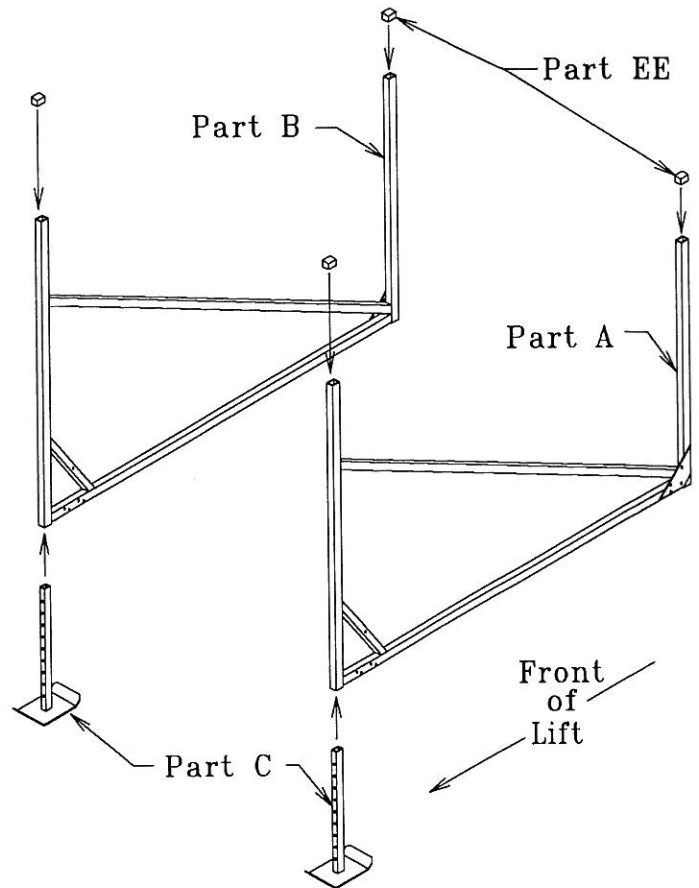

#3 Place A part (left side) and B part (right side) about nine feet apart as shown. Attach part E (front bottom beam) to A & B parts as shown. Use three 3/8" x 2 3/4" hex bolts with 3/8" nuts at each end.

Note: The triangular plate welded to the lift sides must face outward to properly attach bottom beams.

Note: The front bottom beam has rectangular shape plates welded on the ends. The rear bottom beam has (nearly) square plates.

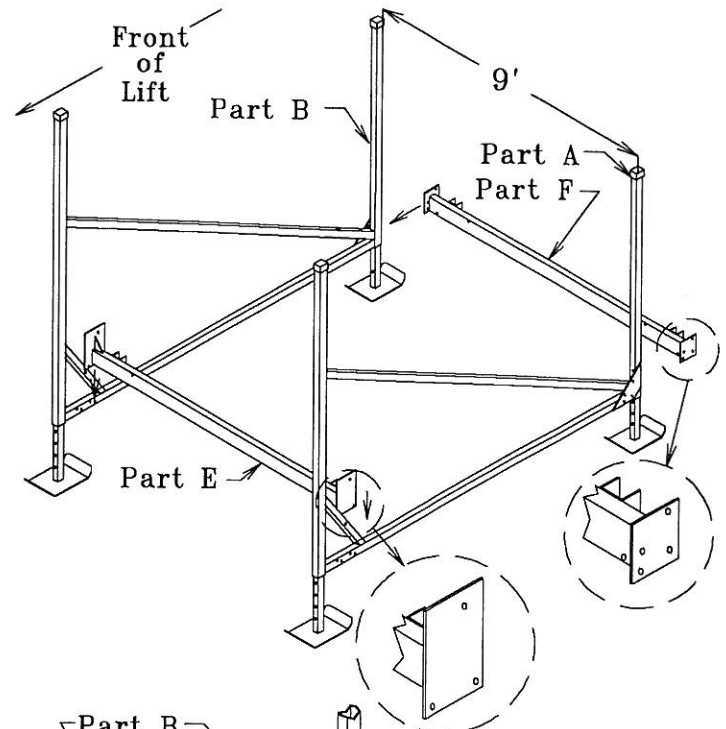

#3B Attach part F (rear bottom beam) to A & B parts as shown. Use four 3/8" x 2 3/4" hex bolts with 3/8" nuts at each end.

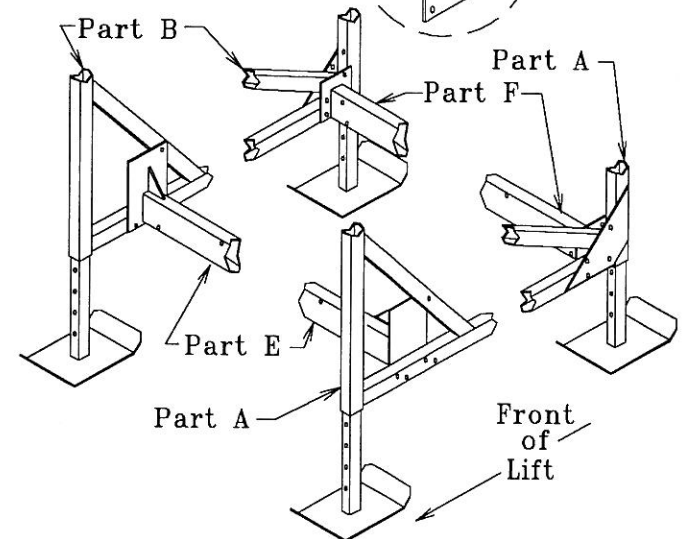

#4 Attach G parts (I-beams) to part E & part F as shown. Use (2) 1/2" x 4 1/2" hex bolts and (2) 1/2" lock nuts per part.

Note: Do not over tighten lock nuts. This connection must move freely during operation.

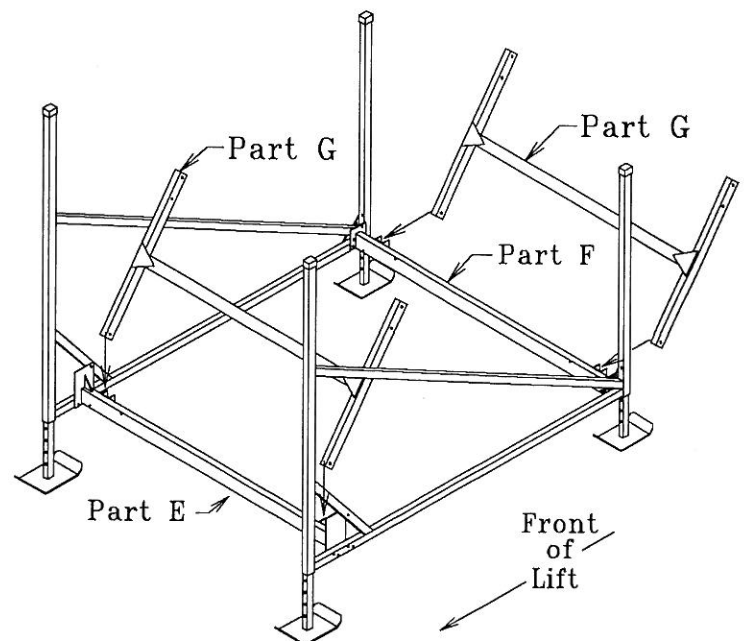

#5 Attach part I (left side brace) & part J (right side brace) to part E (front bottom beam) and to parts A & B (sides) as shown. Use (2) 3/8" x 2 3/4" hex bolts, (1) 3/8" washer and (2) 3/8" nuts for each brace. Bolts should face thread side out.

Note: The washers are used on forked end of brace. Forked ends attach to sides. Place between bolt head and brace.

Note: If lifting a wide pontoon, float boat or deck boat you often cannot use standard braces. They could interfere with your boat fitting in the lift properly.

Note: Lift sides should be at a 90-degree angle to your bottom beam after attaching braces.

CAUTION

Bolt should be placed so threaded side faces out. This prevents cable from catching under bolt threads should you allow slack in cable during use. Not doing this could result in cable fraying from rubbing on bolt threads.

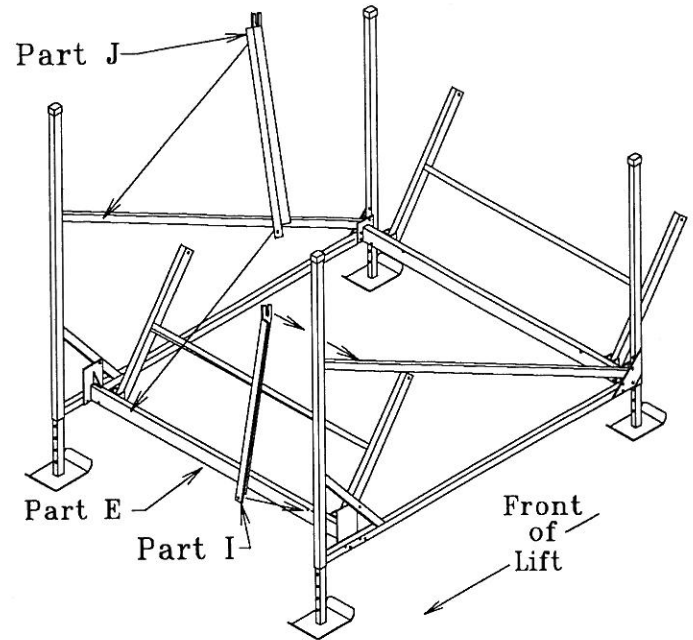

#6 Attach part H (top rack) to parts G as shown. Use four ½" x 4 ½" hex bolts with ½" lock nuts.

Note: Be sure part H is attached exactly as shown. Do not attach upside down or backwards.

Note: Do not over tighten lock nuts. This connection must move freely during operation.

Note: You may want to shorten G parts if you are in permanently shallow water and have a boat that does not draft much water and your craft weighs close to your lift capacity.

*** This is accomplished by cutting 8" off top of G parts, about 1" above hole already drilled in G parts. This will make your lift easier to operate. However, you only have 32" of lift height instead of 40" normally provided.

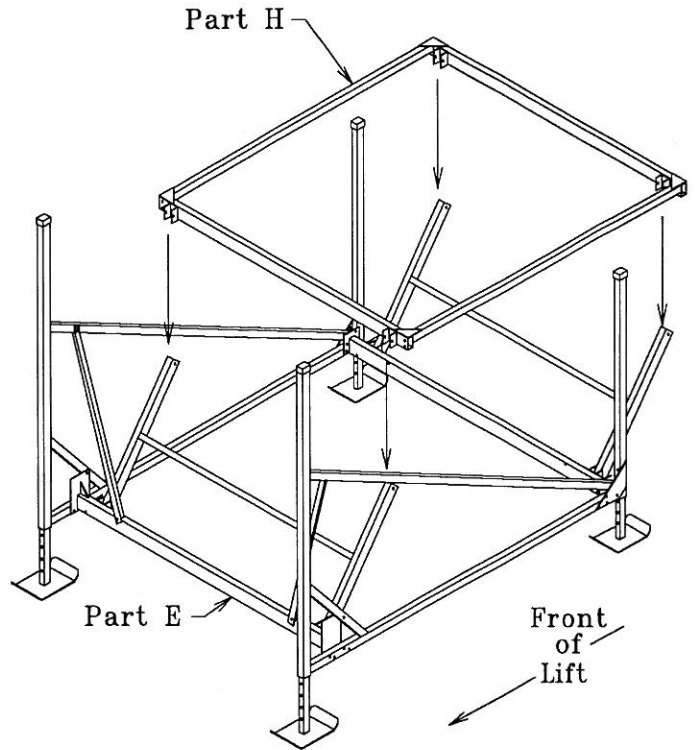

#7 Determine where you will position your lift alongside your dock. The side facing your dock is where the winch and wheel attachment will be mounted.

#8 Tie ropes from part H (lift rack) to parts A or B (side upright) in opposite corners. This prevents rack from pivoting during remaining assembly and during installation.

CAUTION

A freely pivoting lift rack could cause a pinching or cutting injury during installation. Be sure lift rack is properly secured when installing. Never move or lift your boat lift by grabbing the lift rack or I-beams.

#9 Attach BB part (pulley with two link chain) to part A or part B, as determined in step #7. Use (1) 3/8" x 4" U-bolt, (2) 3/8" washers and (2) 3/8" nuts to attach.

Note: The BB part must be attached to the proper side. Attach pulley to the side you will be mounting your winch on.

Note: The washers are placed next to nut when attaching.

#10 Attach (2) AA parts (pulleys with three link chain) to Part H (top rack) as shown. Use (1) 7/16" offset U-bolt, (2) 7/16" washers and (2) 7/16" nuts to attach each U-bolt.

Note: The washers are placed next to nut when attaching.

Note: The long end of offset U-bolt is underneath.

#11 Attach the other 3/8" x 4" U-bolt to the opposite lift side using (2) 3/8" washers and (2) 3/8" nuts.

Note: This U-bolt must be attached to the proper side. Attach it to the side you will **not** be mounting your winch on.

Note: The washers are placed next to nut when attaching.

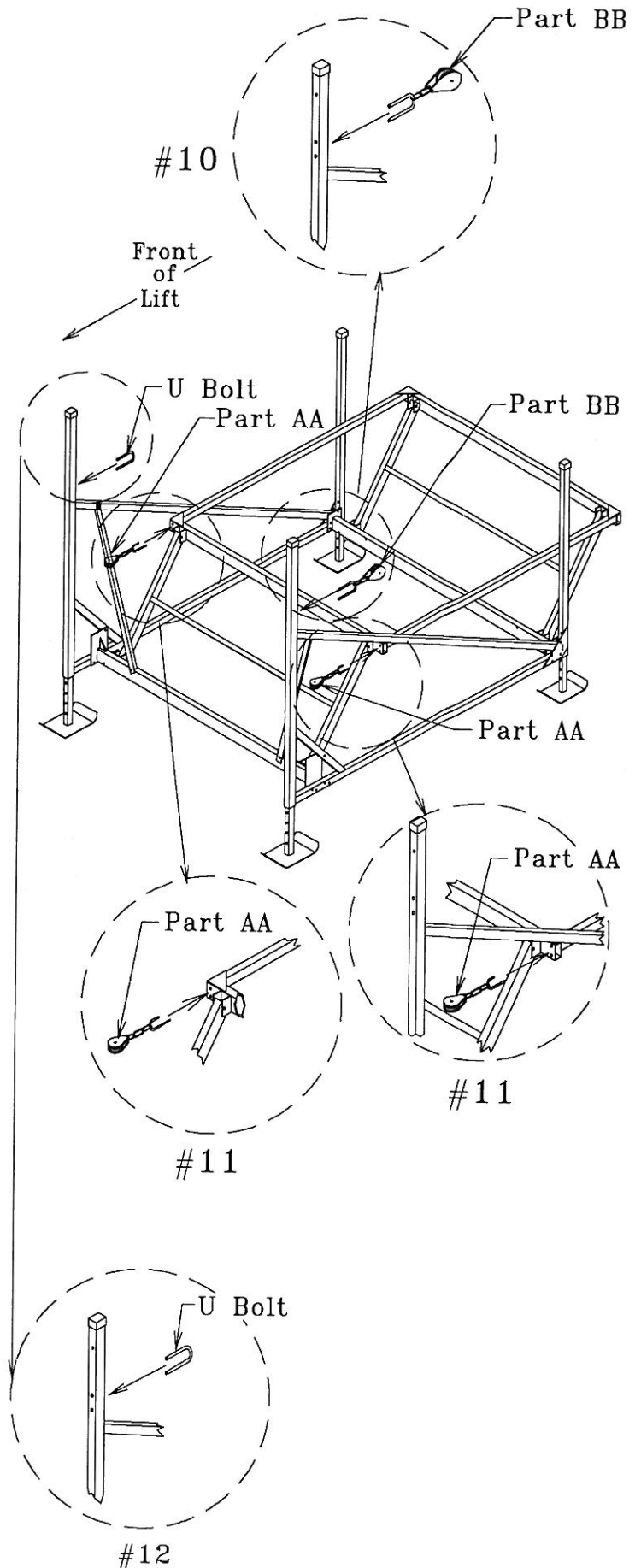

#12 Attach one end of CC part (cable) as shown, to the U-bolt you just attached. Use (2) 1/4" cable clamps.

Note: The proper way to attach clamps is as shown. Saddle of clamp must be against cable leading to pulleys.

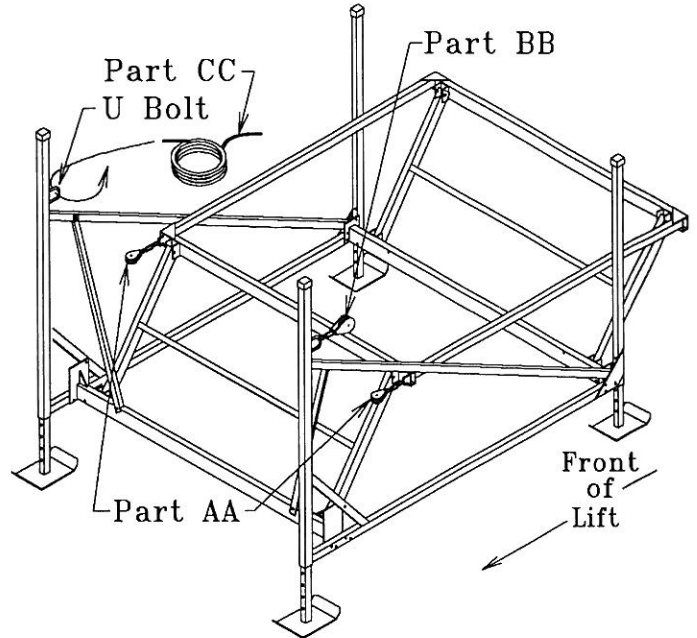
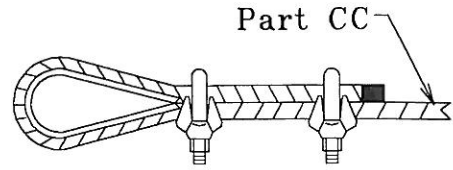

#13 Thread CC part through all three pulleys as shown.

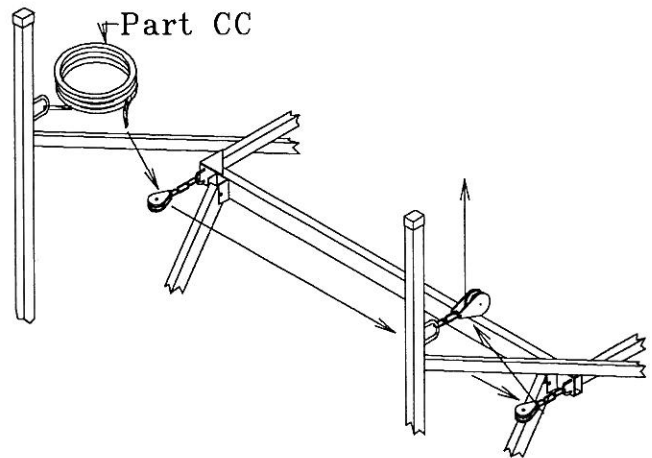

Note Attach CC part to DD part (winch) as shown. Use the 1/4" carriage bolt, 1/4" nut and clamp located in the GG part bag.

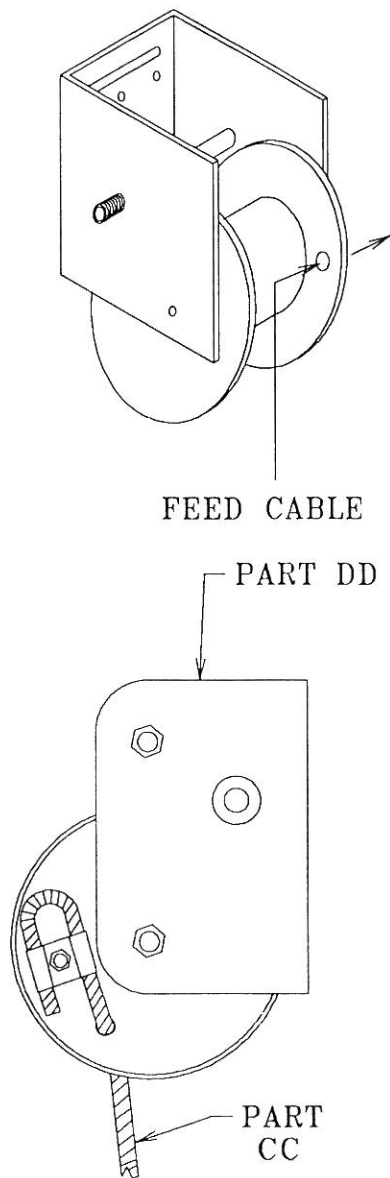

#14 Attach DD part (winch) to upright above BB part (pulley with two link chain) as shown. Use (2) 3/8" x 3 1/2" hex bolts, (4) 3/8" washers and (2) 3/8" nuts.

Note: Use two washers on each bolt. One against bolt head and one against nut.

CAUTION

Be sure winch and winch hub are attached exactly vertical when tightening bolts and nuts. Attaching crooked could result in premature cable wear.

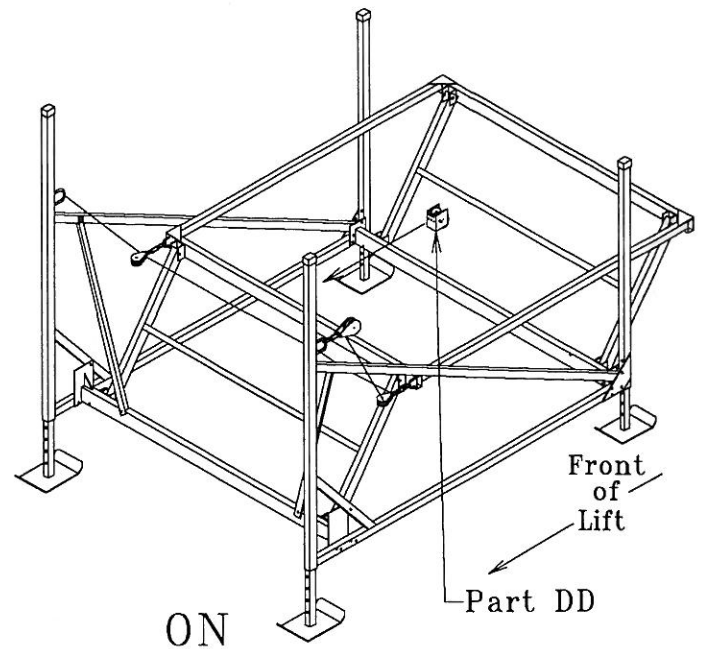

#15 Thread L part (wheel) clockwise on to shaft of DD part. Secure in place as shown by attaching 5/16" hex bolt, washer and spacer located in GG part bag.

Note: You will need to cut a small round hole in middle of wheel sticker to attach bolt.

Note: Do not over tighten this bolt. You could break bolt if you over tighten or cause the brake to function improperly.

Note: You must thread wheel all the way on winch shaft. The wheel hub must be up fully against brake pad and a clicking sound must be heard when turning wheel up!

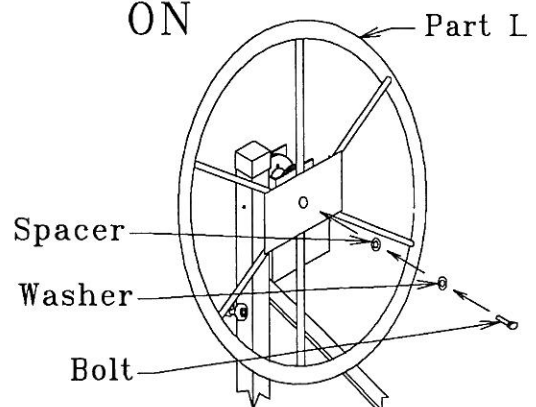
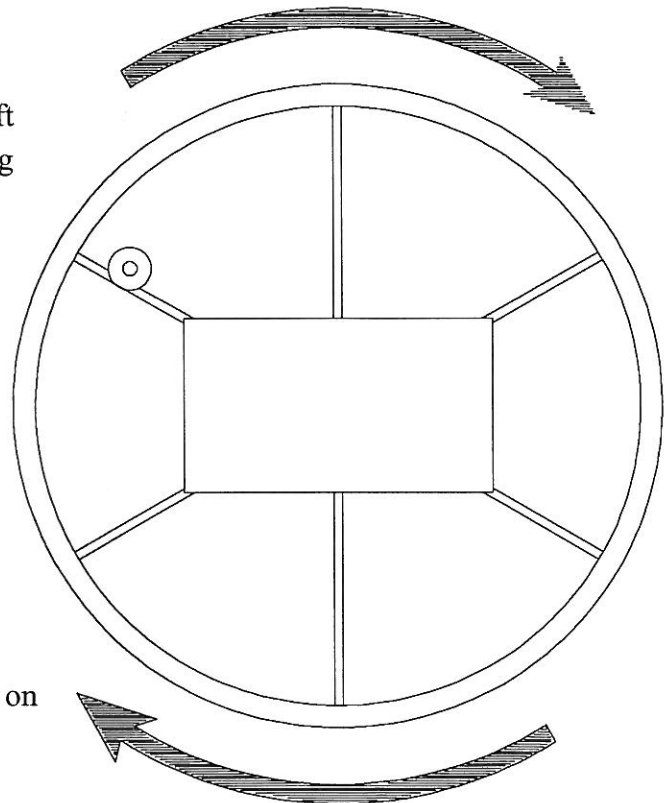

#16 Thread excess cable onto winch hub by turning wheel clockwise at this time. Applying tension to cable, by holding it tight when raising wheel, will help to develop proper wrap.

CAUTION

Be sure cable wraps tight and uniformly on hub.

Do not allow cable to wind up loosely on hub. Cables wrapping incorrectly will result in rapid cable wear.

CAUTION

Use a leather glove or other hand protection to avoid cuts when applying cable pressure.

#17 Firmly secure bolts and nuts at this time. Do not over tighten lock nut connections.

#19 Many accessories are available for use with this boat lift. See assembly instructions for each required accessory. Follow relevant safety instructions mentioned in this manual when attaching accessories.

INSTALLATION

The following are guidelines or suggestions for installation. Situations vary between installation sites. Common sense may dictate that other factors be considered in your situation. Your site may not allow for some of our suggestions to be used or followed entirely. Do not, under any circumstances, endanger yourself or risk damage to lift or boat when installing.

CAUTION

If you are unable to properly and safely install this boat lift, **please have a trained boat lift installer perform the installation.**

#1 Measure water depth of exact position you want to locate lift.

#2 Before installing, adjust lift legs so lift can be properly positioned in water.

Note: Lift must be positioned low enough so boat can float into position before raising, while also allowing high enough position so the boat can be fully raised up and out of water.

Note: Lift rack must always be in partially raised position before any weight is applied (6" above rear bottom beam). Lift rack must never rest on rear bottom beam during use. Adjust lift legs down or move lift to deeper water if this is a problem!!!

CAUTION

Never apply weight on lift when top rack is in fully lowered position. Doing this will bend lift frame and cause permanent damage to lift.

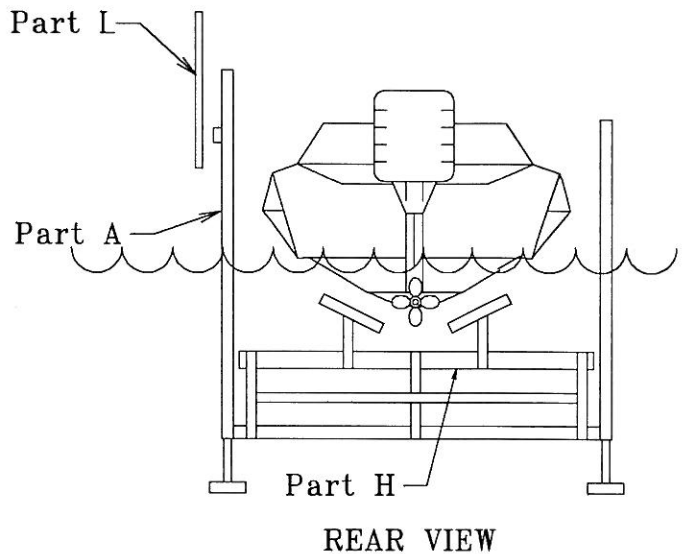

#3 Be sure security ropes are still in place. This will prevent rack from pivoting when moving lift into position.

Note: Remove ropes when lift is in place.

CAUTION

A freely pivoting lift rack could cause a pinching or cutting injury during installation. Be sure lift rack is properly secured when installing. Never move or lift your boat lift by grabbing the lift rack or I-beams.

#4 Carry, lift, roll, float or slide lift into position. Position alongside dock so hand wheel can be easily turned from dock.

CAUTION

Lift must be resting on lake bottom in a level, secure and stable position for safe operation. An unstable lift installation could result in tipping of lift during operation, causing damage to watercraft, and crushing or pinching injury to operator.

OPERATION

-Loading of Watercraft-

CAUTION

Remove safety ropes before using lift. Be sure when removing that cable is wrapped tight. Winch up excess cable to avoid rack dropping when undoing ropes.

#1 Be sure lift rack and cradles or bunks are positioned below water surface so they will not interfere with boat floating into position.

CAUTION

Be sure boat is properly balanced and centered on lift before raising.

CAUTION

If lift is without a boat in it for more than one day, raise the rack (pulleys and cable) fully out of the water to help prevent corrosion of these parts.

#2 Position boat with center of gravity near middle of lift. For most rear engine mounted boats, this requires you to position the boat mostly forward in the lift.

WARRANTY DOES NOT APPLY IF DAMAGE IS CAUSED BY IMPROPER LOADING!!

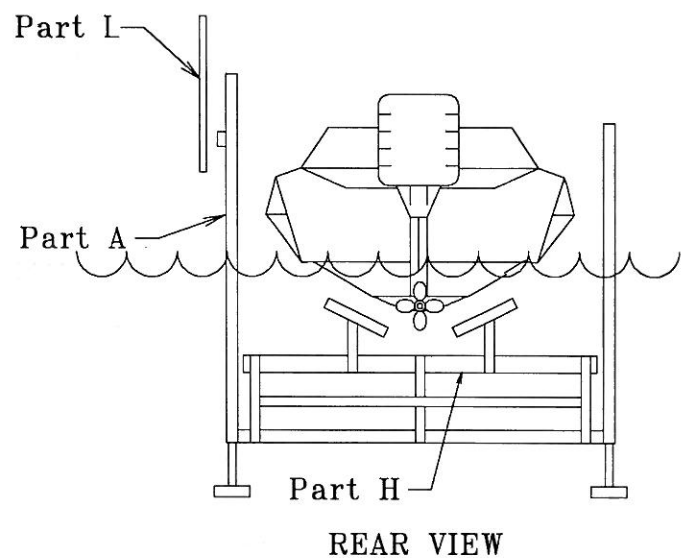

-Raising Lift-

#1 Make sure boat is in proper position. Turn lift wheel clockwise (in direction of up arrow). Stop turning wheel when craft reaches desired height out of the water.

WARNING

Stay clear of lift (facing wheel) while operating. Do not allow anyone on, in or under lift. A cable or lift part failure can cause a sudden drop of boat, resulting in a crushing or falling injury or death!

CAUTION

Turn wheel in direction of arrow (clockwise) to raise lift. A clicking sound is heard when properly raising lift. Turning wheel and wrapping cable in wrong direction will cause fast spin down of wheel.

CAUTION

If fast spin down of wheel occurs do not touch wheel or attempt to stop. Placing hands or feet on spinning wheel can cause broken or cut limbs.

CAUTION

Properly cover your boat, when in raised position, if rain can gather in your craft. An inch of rain adds several pounds to lift. Added weight may result in boat being over capacity.

CAUTION

Do not over raise lift rack. If wheel is over rotated and rack is over raised it could cause damage to lift and may leave you unable to lower lift back down.

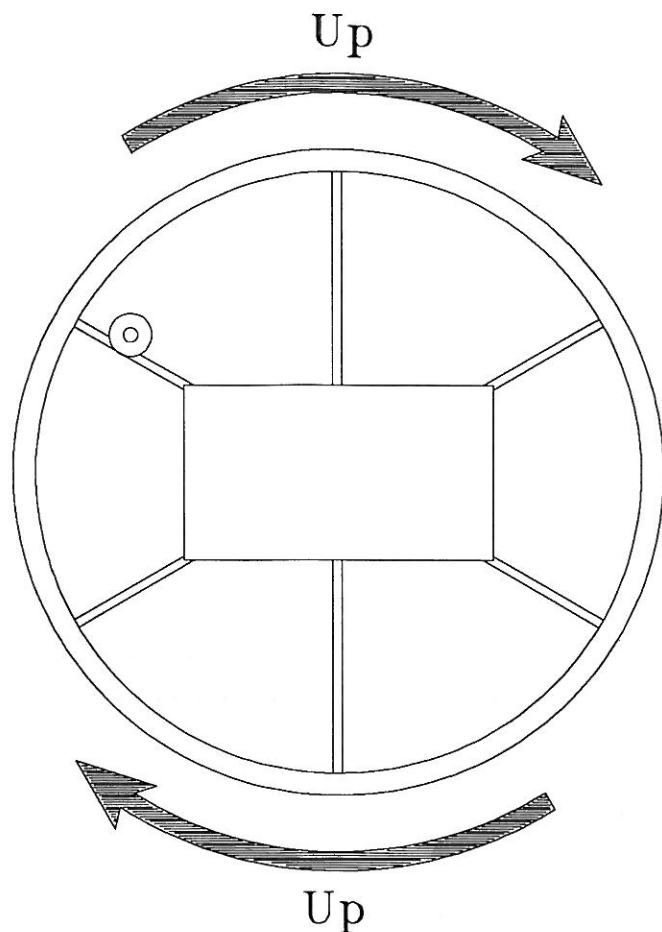

#2 Optional: Lock and chain wheel for security.
You may also lock and chain rack to both front lift uprights to secure boat from cable or winch failure.

CAUTION

Do not allow people on boat when in a raised position on lift. Entering boat when in the raised position adds to lift load and is not safe! A falling injury could occur should lift fail.

CAUTION

Do not allow anyone who is in the water within six feet of the lift. A crushing injury could occur to swimmer should cable, winch brake or lift part fail.

-Lowering Lift-

#1 Turn wheel counterclockwise (in direction of down arrow).

Note: Turn wheel down one or two turns past point when craft begins to float (This must always be at some point before lift rack is contacting rear bottom beam). Then turn wheel up slightly until clicking sound is heard to secure wheel position and brake on winch.

CAUTION

Winch Safety - Never disconnect ratchet pawl, gear or brake mechanism to lower lift wheel.
Disconnected or faulty brake parts will result in rapid spinning of wheel.

CAUTION

Do not over lower wheel so slack develops in cable. Doing this could cause cable to jump off winch spool. This may result in sloppy wrapping of cable next time you raise the lift, resulting in premature wear or cable breaking.

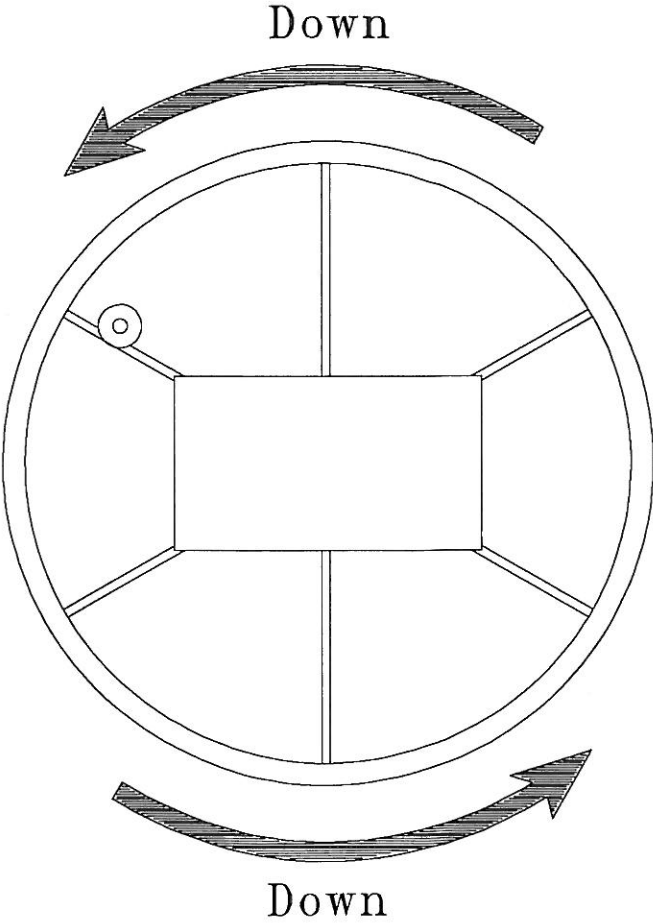

REMOVAL & STORAGE (winterizing)

****Warranty does not cover this product against any damage caused by or related to ice!!**

CAUTION

Ice can severely damage your boat lift. Do not leave lift, or boat on lift, in water if ice damage is possible.

#1 Tie lift rack securely to lift side uprights in opposite corners. This will prevent rack from pivoting when moving lift out of water.

Note: Remove ropes when lift is reinstalled.

CAUTION

A freely pivoting lift rack could cause a pinching or cutting injury during removal. Be sure lift rack is properly secured when removing. Never move or lift your boat lift by grabbing the lift rack or I-beams.

#2 Carry, lift, roll, float or slide lift out of water. Position safely away from potential ice build up.

SERVICE (Maintenance)

#1 Inspect nuts and bolts at least every six months for damage, wear or loose connections. Tighten or replace parts as needed.

CAUTION

Check cable for frays, corrosion or breaks at least once a month. A cable breaking while boat is in lift could damage boat or lift. Severe bodily injury could also occur.

#2 Inspect lift frame, pulleys, winch and pivot points at least every six months for unusual wear, damage or bent parts. Replace or repair as needed.

#3 Lubricate winch and wheel threads at least every six months.

Note: Do not get lubricant on brake pads! Brake will fail and wheel will spin down if brake pads are lubricated.

#4 Lubricate pulleys at least every six months.

#5 ShoreMaster dealers usually offer service visits. Please contact them if you are unable or unwilling to perform maintenance or service to lift.